

Gears – Tasks Primary level

Dirk Fox

We will start with a simple rack and pinion gear, and then we'll be learning about other types of gears. Finally, we will be building simple transmission gears.

Topic

Gear for changing the direction of movement, changing the location and speed. Finally, we will be looking at two important gearing mechanisms that change the type of movement.

Learning objective

- Understanding gearing mechanisms for changing direction of rotation
- Understanding how to calculate gearing mechanisms that change the movement speed (accelerate or decelerate)
- Constructing gearing mechanisms to change the type of movement

Time required

Building each of the gearing mechanisms should not take more than 10-15 minutes. Then, the results should be briefly evaluated and discussed (5 minutes). The total time for all six tasks is estimated to be two school periods (2 x 45 minutes); the time required to explain the background information on gears (definition, function, history) that can be mixed with the tasks is estimated to be another school period.

Gears Task 1 – Toothed gear and belt drives

Construction task

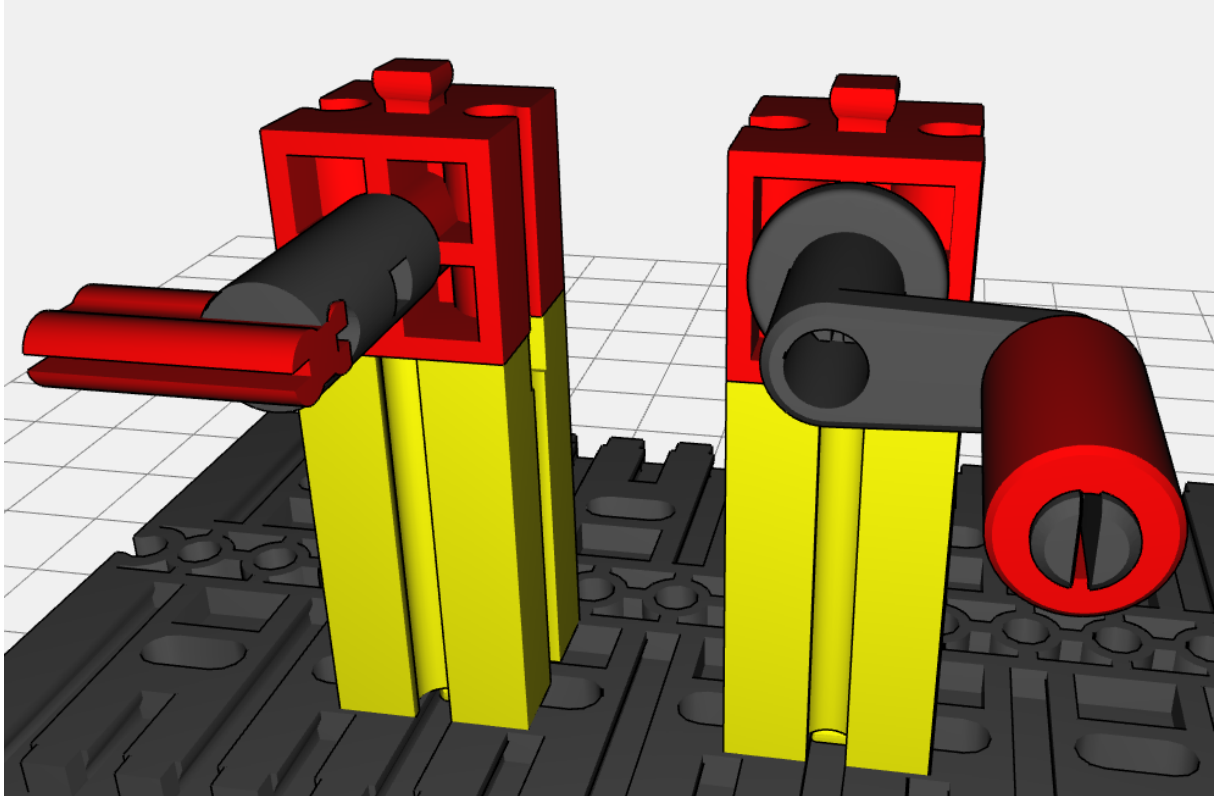

On the image, you can see two axles connected in parallel. One of these is the input (crank) and the other is the output (small “flag”). Add a gearing mechanism to the construction made of toothed gears so that the two axles turn in opposite directions when you turn the crank.

Experimental task

1. How can you add to the gear drive so that the two axles turn in the same direction?
2. Does the movement of the output shaft change if you use another third toothed gear?
3. How can you solve experimental task 1 using a chain or a rubber band instead of the toothed gears?
4. How can you change your rubber band gearing mechanism so that the axles turn in opposite directions from one another?

Solution sheet

Gears Task 1 – Toothed gear and belt drives

There are different solutions for some of the experimental tasks, each of which have advantages and disadvantages. Students should compare and evaluate these solutions. Calculating the gearing ratios between input and output drive (task 5) is a good and practical application for fractions.

Construction task

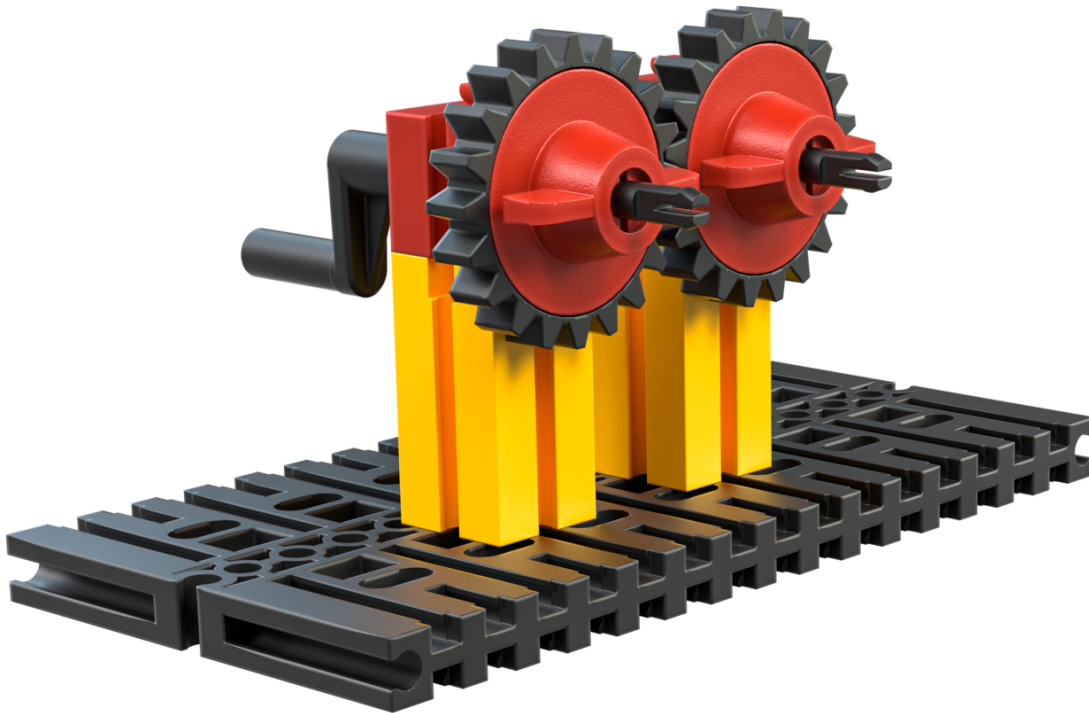

Experimental task

1. The direction of rotation can be reversed with an additional toothed gear (or any uneven number of toothed gears), so that the axles turn once again in the same direction.

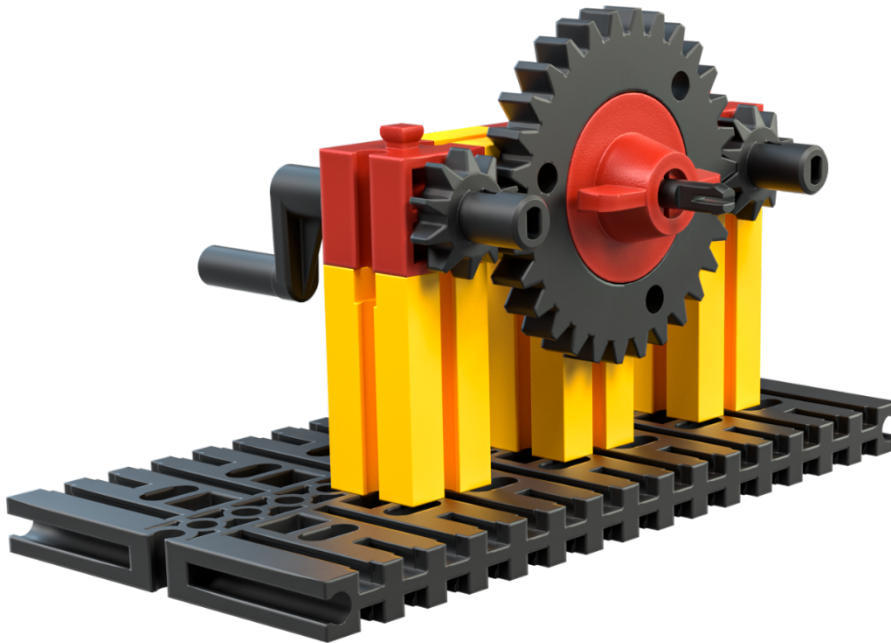

2. The movement of the output axle does not change if the Z30 is replaced with another toothed gear.
3. The direction of rotation remains the same with a belt drive and chain drive.

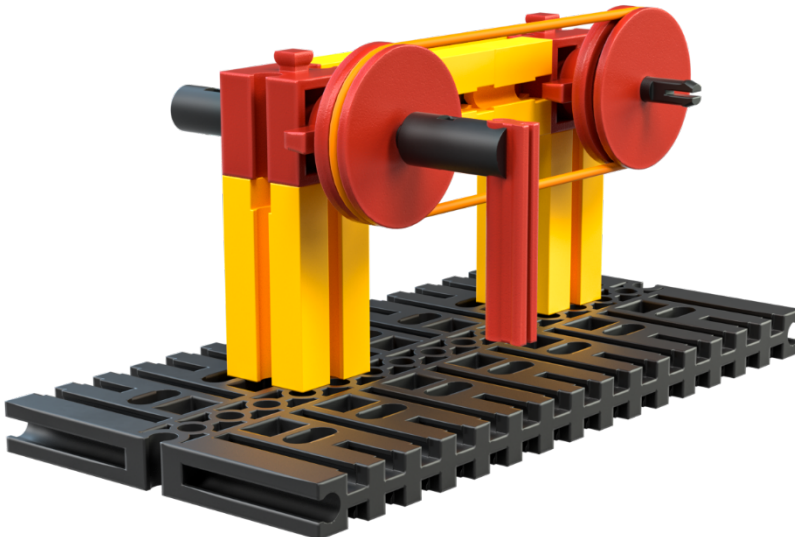

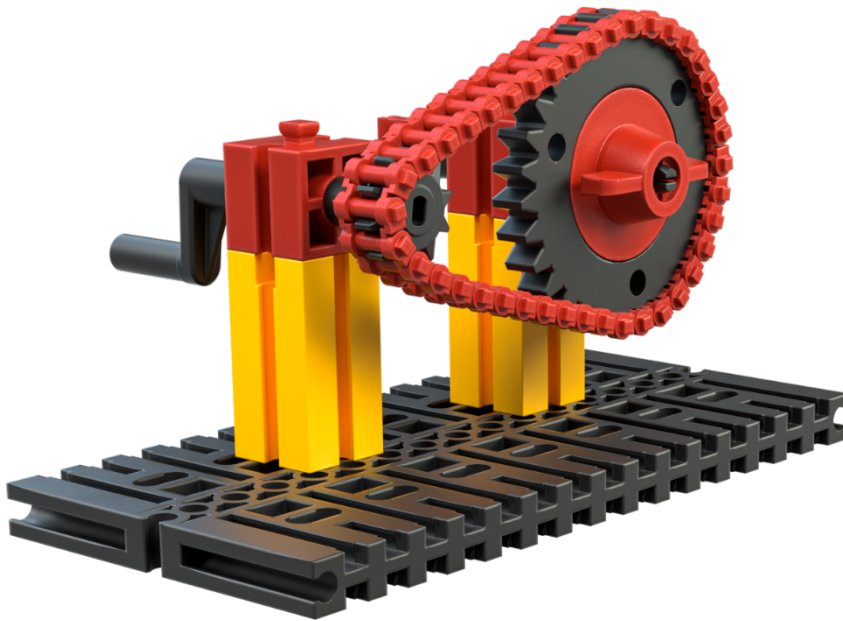

4. The direction of rotation can be reversed by crossing the belt drive (rubber band).

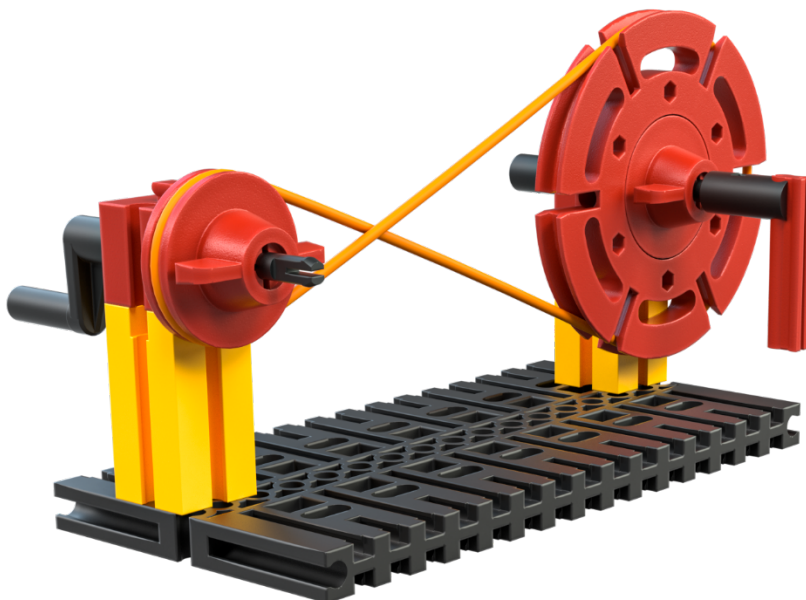

Gears Task 2 – Cone gear wheel and crown wheel gear

Construction task

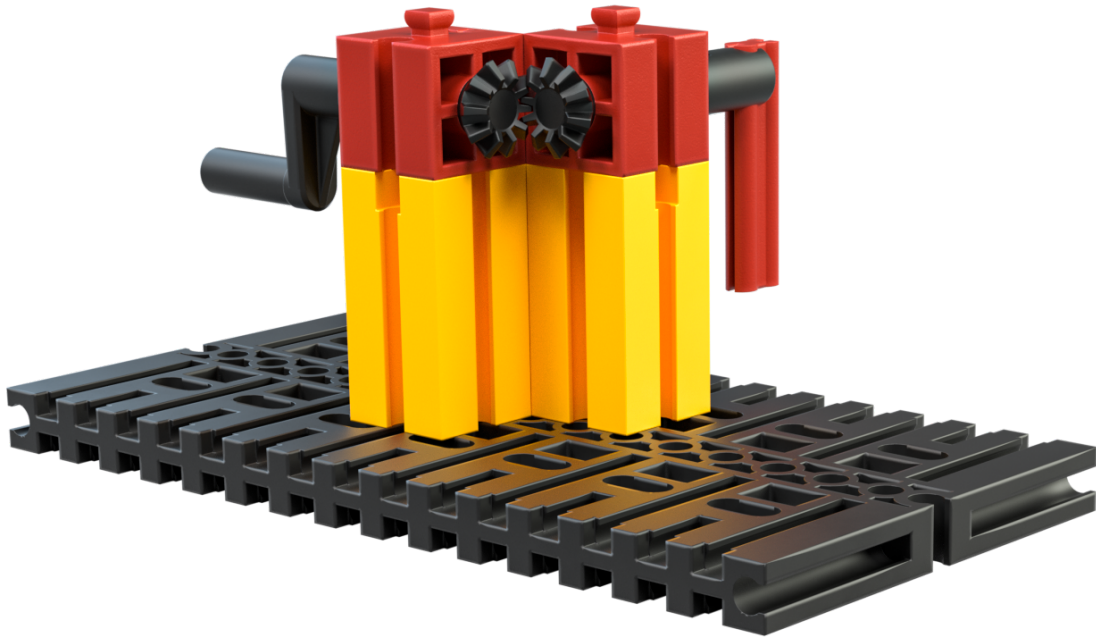

Fig. 2 Cone gear wheel

Build the gearing mechanism shown in the image. Toothed gears that meet at a right angle (90°) and interlock with one another are called cone gear wheels.

Topic question

Observe the output axle and turn the crank. Which of the axles (input/output) turns faster? Why?

Experimental task

1. Try to build another “ 90° gearing mechanism” using the gear components from the set without cone gears wheels.
2. Describe your construction. Observe the output axle and turn the crank. Which of the axles (input/output) turns faster? Why?

Solution sheet

Gears Task 2 – Cone gear wheel and crown wheel gear

There are different solutions for some of the experimental tasks, each of which have advantages and disadvantages. Students should compare and evaluate these solutions. Calculating the gearing ratios between input and output drive is a good and practical application for fractions.

Topic question

Both axles turn at the same speed, since the number of teeth on both cone gear wheels (10) is identical (no gearing ratio).

Experimental task

1. Instead of the cone gear wheels, you can build a crown wheel gear with a Z40 and, for example, a Z20.

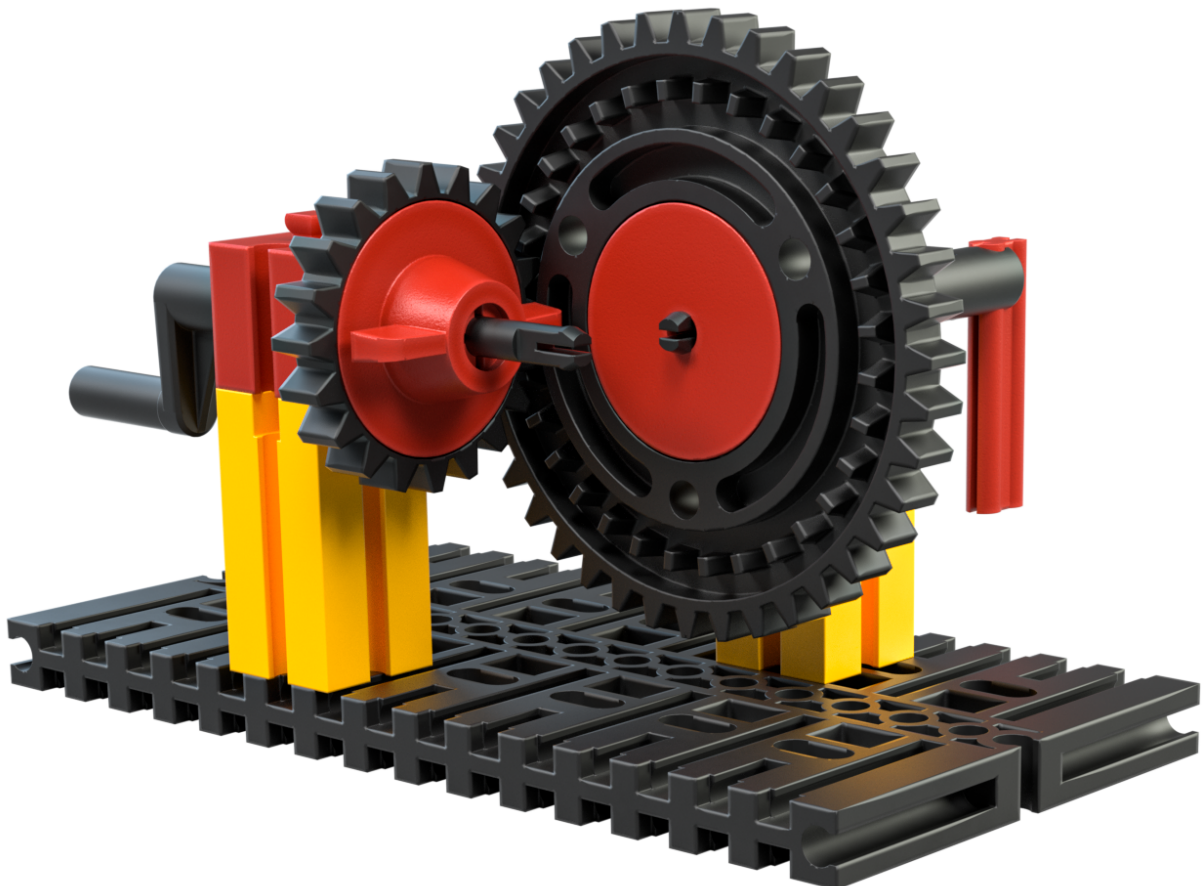

Gears – Classroom set Primary level

The following rack and pinion gear is an alternative construction. Here as well, the rotational movement is transformed by 90° when you understand the second crank as the output shaft. Disadvantage of the gearing mechanism: The length of the rack is limited.

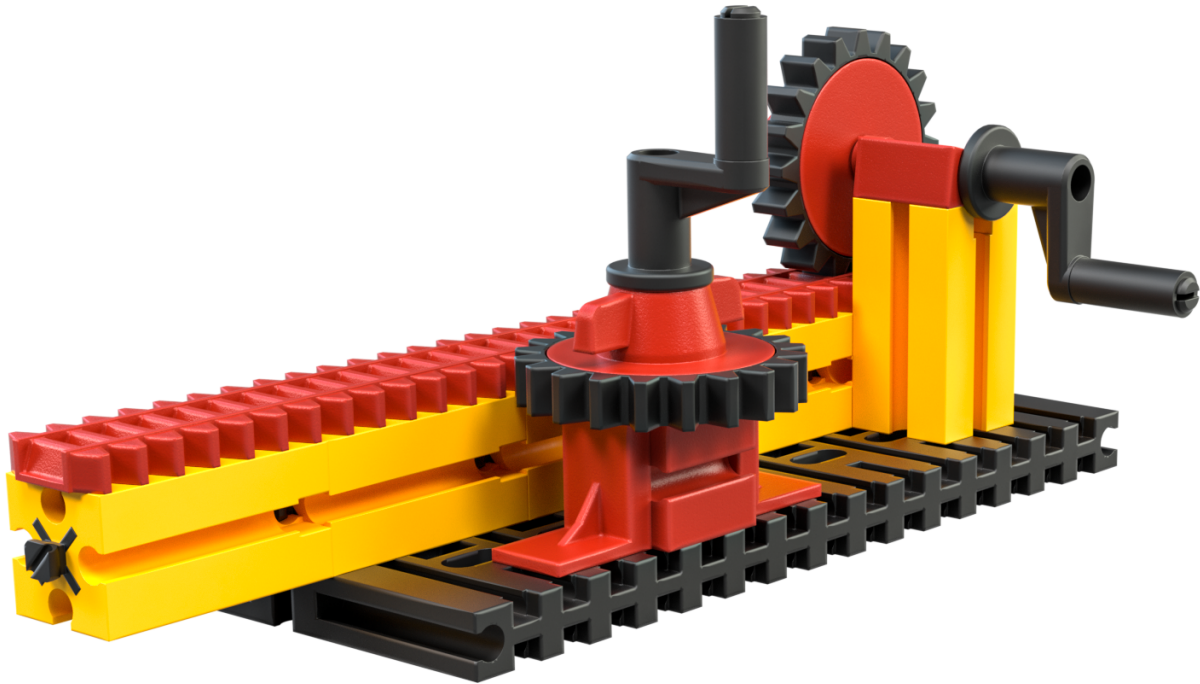

2. When building the crown wheel gear, the gearing ratio is 20:32, gearing down (or, abbreviated: 5:8). This means that the Z20 turns eight times, while the Z40 makes five revolutions. This can very easily be checked via experiments using a coloured sticker on the toothed gears and counting during cranking.

In a rack and pinion gear, the input and output axles turn at the same speed.

Gears Task 3 – Transmission gearing (I)

Construction task

Build a gear drive in which the output axle turns twice as fast as the input axle (your crank).

Topic question

What determines how fast the output axle turns in comparison to the input axle?

Experimental task

1. Experiment with different combinations of toothed gears. How can you calculate the rotational speed of the output axle (in comparison to the input)?
2. Can you build this kind of transmission gearing, in which the output axle turns faster than the input, using another gearing principle?

Solution sheet

Gears Task 3 – Transmission gearing (I)

There are different solutions for some of the experimental tasks, each of which have advantages and disadvantages. Students should compare and evaluate these solutions. Calculating the gearing ratios between input and output drive is a good and practical application for fractions.

Construction task

The construction task can be solved by a gearing ratio of a Z20 to a Z10, or by a Z40 to a Z20.

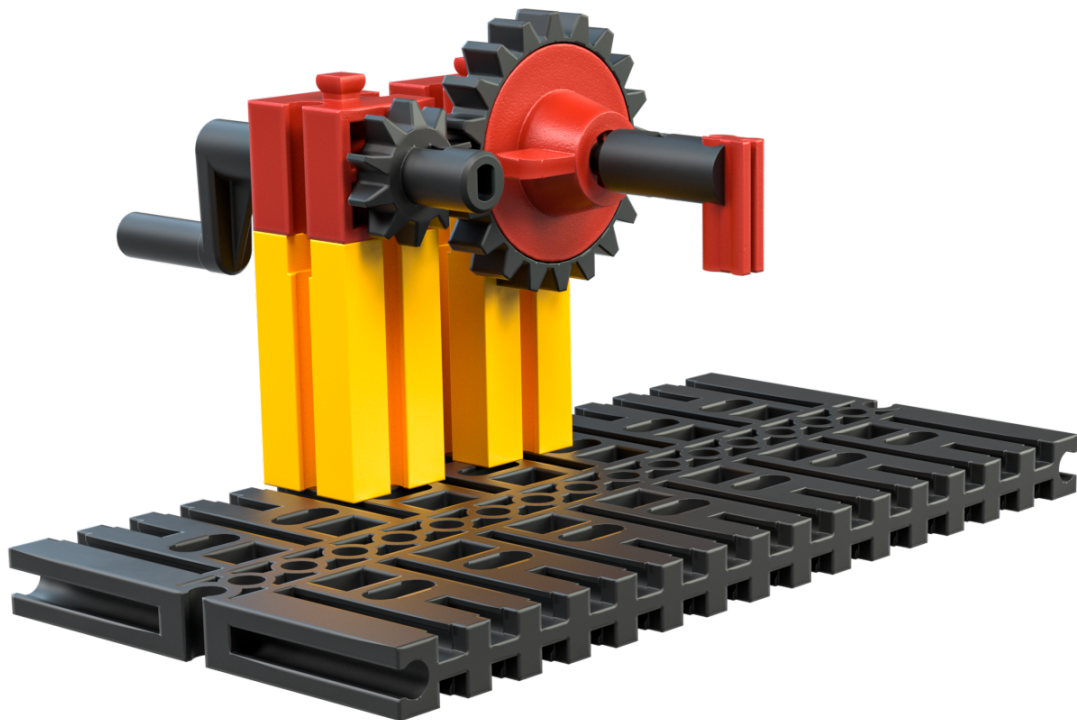

Topic question

The difference in speed is expressed in the ratio between the teeth on the two toothed gears.

Experimental task

1. By dividing the number of teeth of the toothed gears involved in the transmission:
The number of teeth on the toothed gear on the input shaft, divided by the number of

Gears – Classroom set Primary level

teeth of the toothed gear on the output shaft equals the factor by which the output axle is accelerated or slowed in contrast to the input axle.

2. This works, for instance, with a hub 60 on the input axle and a hub on the output axle, connected via a rubber band.



The same can be accomplished with a chain drive using a Z20 (input) on a Z10 (output) or a Z40 on a Z20.

Gears Task 4 – Transmission gearing (II)

Construction task

Build a gear drive in which the output axle turns half as fast as the input axle (your crank) – It is simple to do.

How can you modify the gearing mechanism from the construction task in task 3 so that the output axle turns 12 times as fast as the input axle.

Experimental task

1. Try to use the components available to you to build a gearing mechanism that drives the output axle as quickly as possible.
2. Can you determine the speed of the output axle in relation to the input axle – by counting the rotations, or perhaps through calculating?

Solution sheet

Gears Task 4 – Transmission gearing (II)

There are different solutions for some of the experimental tasks, each of which have advantages and disadvantages. Students should compare and evaluate these solutions. Calculating the gearing ratios between input and output drive is a good and practical application for fractions.

Construction task

The construction task can be solved by a gearing ratio of a Z10 to a Z20, or by a Z20 to a Z40 (simply exchange the input and output axles by removing and re-inserting the crank).

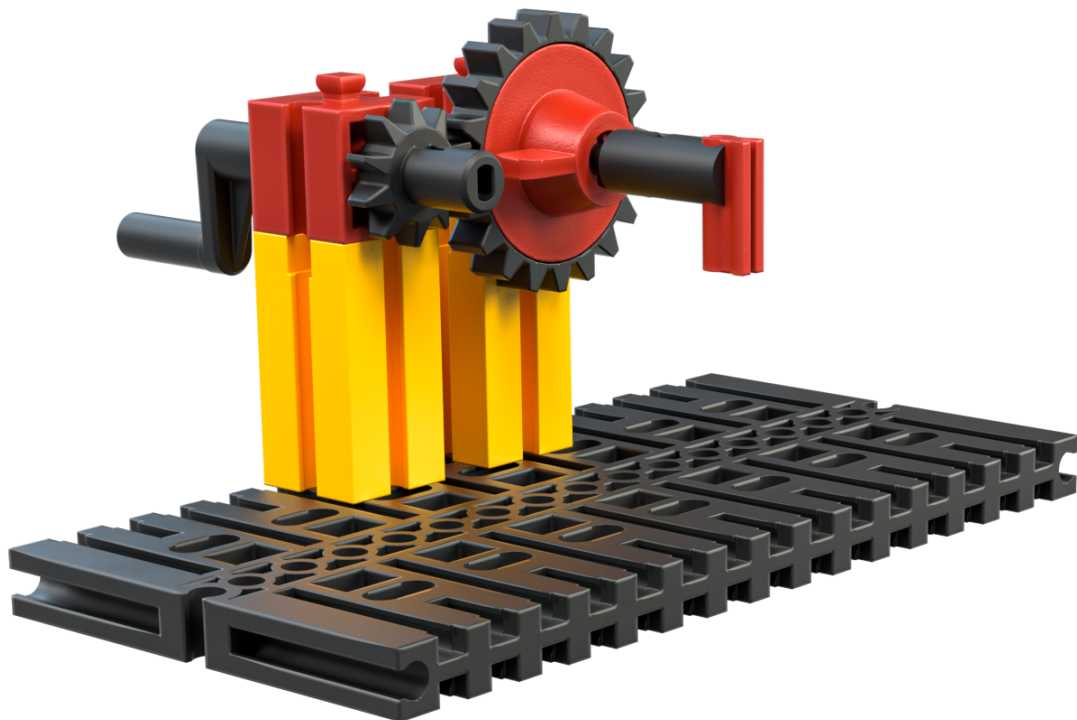

The expansion of the gearing mechanism from task 3 could, for instance, look like the following:

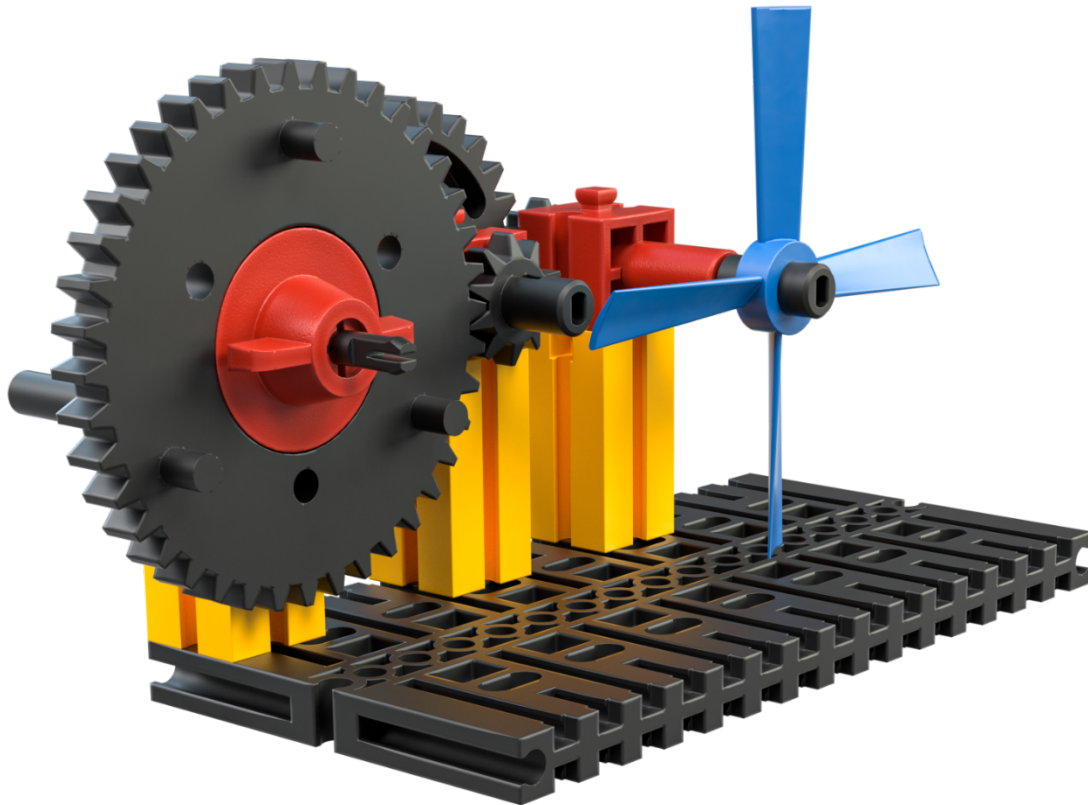

A chain drive can also be used.

You obtain the gearing ratio for the entire gear mechanism by multiplying each additional gearing ratio with the previous one. The gearing ratio is then calculated from the number of teeth on the toothed gears as follows: $40:10 \times 30:10 = 4:1 \times 3:1 = 12:1$.

Experimental task

1. The construction of the 12:1 gearing mechanism can be expanded by additional gearing ratios (such as another 20:10 gearing ratio). A chain or even belt drive can be added here as well.
2. With an additional 2:1 gearing ratio, the output axle would turn 24 times as fast as the input axle.

Gears Task 5 – Transmission gearing (III)

Construction task



Fig. 3 Worm gears

Build the worm gear shown in figure 3. This unique kind of gearing mechanism is “self-locking”, which means that the output axle can only be moved by setting the input axle (the worm gear) in motion using the crank.

Experimental task

1. Add additional gear elements to the gearing mechanism so that the output axle turns as slowly as possible.
2. Determine the speed of the output axle in relation to the input axle – by counting the rotations, or, even better, through calculating?

Solution sheet

Gears Task 5 – Transmission gearing (III)

There are different solutions for some of the experimental tasks, each of which have advantages and disadvantages. Students should compare and evaluate these solutions. Calculating the gearing ratios between input and output drive is a good and practical application for fractions.

Experimental task

1. The axle of the Z30 can be used, for instance, to add a gearing ratio, gearing down of 10:40 (Z10 to Z40), and from there further gearing down of 10:20 (Z10 to Z20).
2. Overall, this results in a gearing down of $1:30 \times 1:4 \times 1:2 = 1:240$.

Solution in group work:

A much greater gearing down can be achieved if a Z40 is mounted on the output axle of the worm gear instead of the Z30. If you attach another worm gear to the output axle, which in turn drives a Z40, and attach another worm gear to its output axle that drives a Z40 (and so forth), then you will achieve a gearing down of $(1:40)^n$ with $n =$ number of worm gears.

The large building panel can be used to build such an “infinity machine”.

References:

Wolfgang Bürger: *Nur zwölf Stunden bis zur Ewigkeit*. Spektrum der Wissenschaft, 2/2004, p. 102-103. (<https://www.spektrum.de/pdf/sdw-04-02-s102-pdf/835752>)

Arthur Ganson: *Maschine mit Granit (machine with concrete)*, Youtube, <https://youtu.be/8jeQ1gK1J-E>

Remadus: *Die Ewigkeitsmaschine*. Youtube, <https://youtu.be/AZ3EDa-qM34>

Dirk Fox: *Die Ewigkeitsmaschine*. ft:pedia 1/20215, S. 41-43. (<https://ftcommunity.de/ftpedia/2015/2015-1/ftpedia-2015-1.pdf#page=41>)